

# LETMOBEL

CABINET LINE



# CLOSET CABINETS

Frameless

MADE IN USA



## Quality

**Our frameless cabinets** are designed and built to the highest standard of the industry. We source top quality raw materials domestically in North America and perform all the manufacturing also in the USA. Assuring in this way the quality of the final products.

We build cabinets using European hardware, all our hinges, drawer guides and additional accessories are sourced from top Italian brands, which gives our closet cabinets the looks and feel of a leading product.

All our cabinets comply with the **TSCA Title VI EPA** rule and the **CARB ATCM** Phase II emission standards.

## Service

The fact we source our raw materials and manufacture 100% in the US, warranties excellent real lead times for initial purchases, and short response time when needed.

## Simplicity and Efficiency

We build our cabinets with the installer and the builder in mind. **Our products are designed to reduce assembly and installation time**, at the same time we utilize smart hardware to simplify final set up.

By utilizing the latest fastening technology, we reduce assembly labor **cost by 60%**, at the same time that eliminate the need screws, staples and glue.

All our closet cabinets are mounted on polymer adjustable legs, which make installation and alignment super simple, eliminating the need of shims. **This reduces the installation time considerably.**

Since we have **direct access to TFL panels**, we manufacture our finished ends with the same designs of the drawers fronts and doors. Reducing the cost of additional panels, and the time to install those at the end of the job.

# CLOSET CABINETS

## Frameless

### SPECIFICATIONS

Door styles and finishes

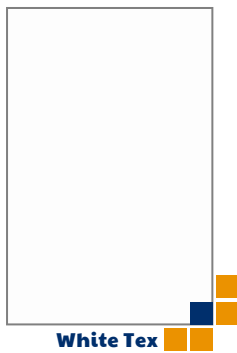

**If you are looking for a particular door color style or finish:**

**Write to us at:** [customerservice@letmobel.com](mailto:customerservice@letmobel.com) • +1- 866 -721.88.37

**We will answer your question in a personalized way.**

# CLOSET CABINETS

## Frameless



### DOUBLE HUNG

**CL2594DH**

25.5WX16DX94.5H

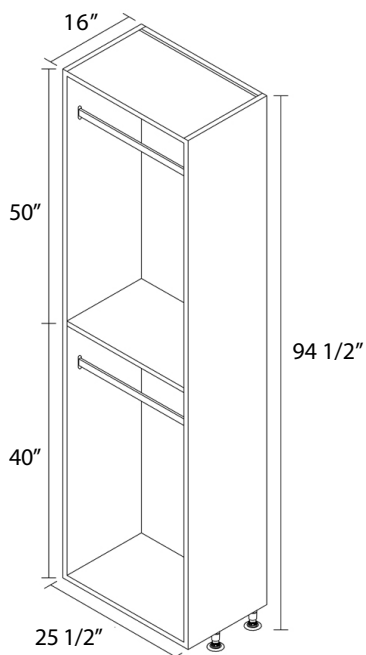

#### Futures

- 1.** Cabinet Box available in Soft Grey and White Tex colors, made of 3/4" PB TFL for maximum strength.
- 2.** Drawer fronts offered in 9 different designs readily available.
- 3.** Finished End Design are matched with Drawer fronts, eliminating the need of additional panels or laminate, reducing overall cost and simplifying installation.
- 4.** 3/8" PB TFL Cabinet Back increases durability and toughness.
- 5.** Adjustable plastic legs makes leveling a breeze and protect box from water leaks.
- 6.** Adjustable Shelves to add versatility, made of 3/4" PB TFL to maximize strength.
- 7.** Concealed High Quality Italian drawer runners with integrated soft-closing mechanism and 6-Way adjustment device for easy install and alignment.

# CLOSET CABINETS

## Frameless

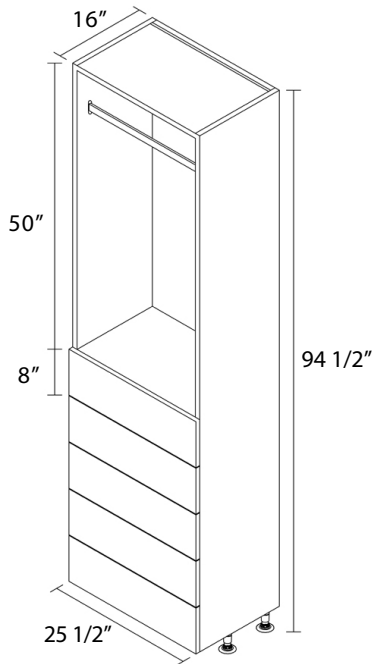

### DRAWER • ROD

**CL2594DR**

25.5W X 16D X 94.5H

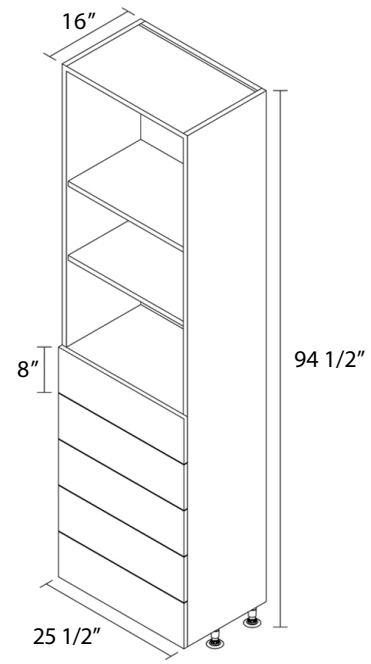

### DRAWER • SHELVES

**CL2594DS**

25.5W X 16D X 94.5H

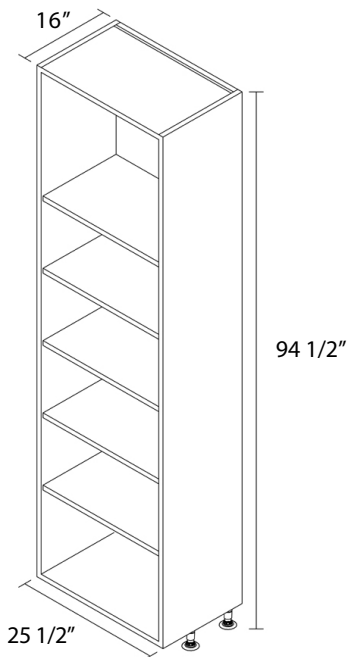

### FULL SHELVING

**CL2594FS**

25.5W X 16D X 94.5H

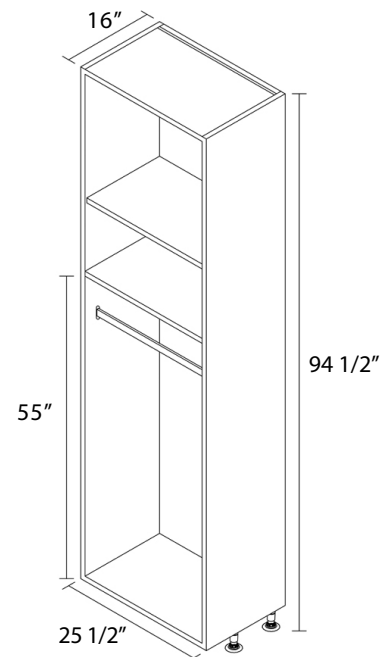

### LONG HANGING

**CL2594LH**

25.5W X 16D X 94.5H



**TSCA TITLE VI COMPLIANT**